

REV.	ECON NO.	MODIFIED MARK	APPROVED
A		FIRST RELEASE	

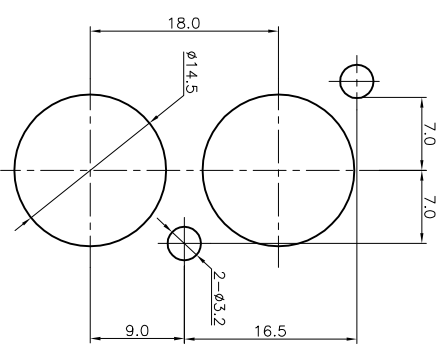
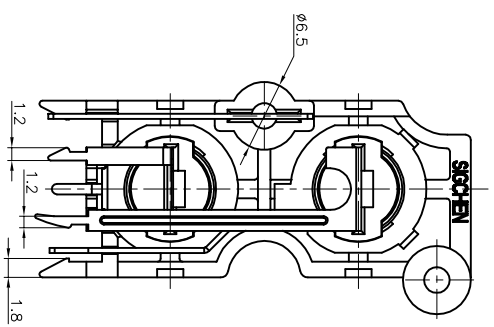
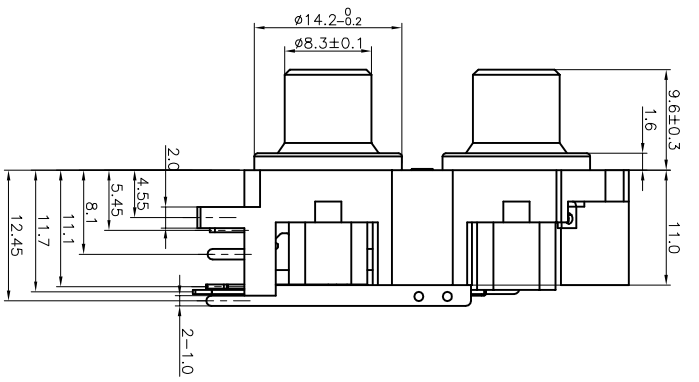
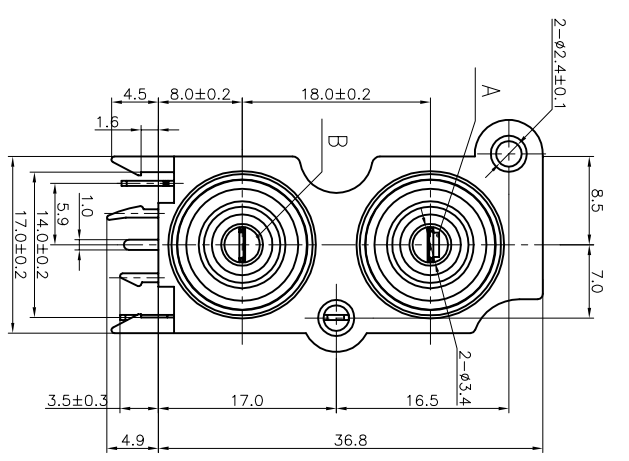

PANEL CUT OUT

Color TABLE

P/N	COLOR
A	BLACK
B	BLACK

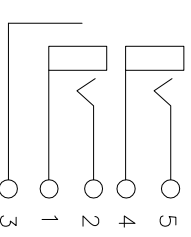

CIRCUIT DIAGRAM

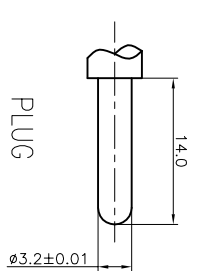

PLUG

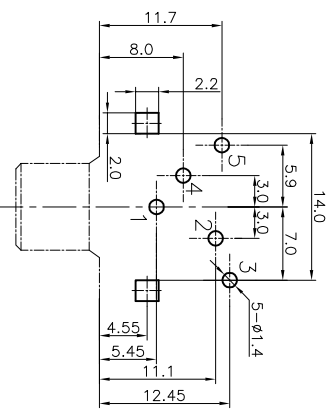
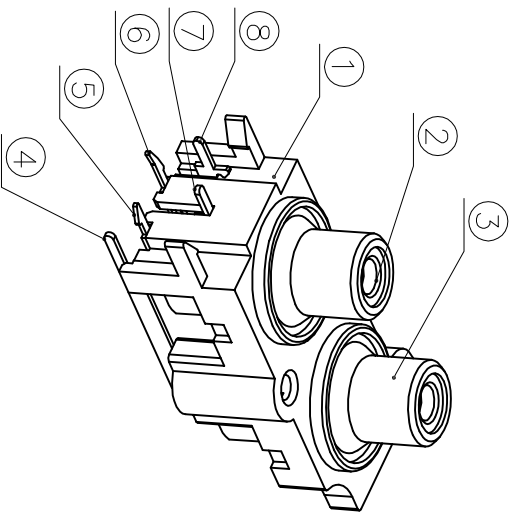

NO.	PART NAME	Q'TY	MATERIAL	FINISH/COLOR	REMARK
⑧	TERMINAL -E	1	BRASS t=0.5	Au PLATED	
⑦	TERMINAL -D	1	BRASS t=0.5	Au PLATED	
⑥	TERMINAL -C	1	BRASS t=0.4	Au PLATED	
⑤	TERMINAL -B	1	BRASS t=0.4	Au PLATED	
④	TERMINAL -A	1	BRASS t=0.5	Sn PLATED	RoHS2.0
③	SOCKET	2	BRASS	Au PLATED	
②	WASHER	2	PBT	BLACK	
①	HOUSE	1	PPO	BLACK	

ANGLE	±5°	MODEL NAME: AV-2-06	TITLE: RCA SOCKET	REV.: A
63 < L	±0.5	(PART NO.)	DWG NO.:	
16 < L ≤ 63	±0.4	MAT'L: See table	CHECKED: B.J.W 2026.02.20	
4 < L ≤ 16	±0.3	FINISH: See table	DESIGN: B.J.W.QIAN2026.02.20	
L ≤ 4	±0.2	Q'TY: See table	APPROVED: C.Q.Wu 2026.02.20	

THIS DOCUMENT IS THE PROPERTY OF GUANCHENG ELECTRON CO., LTD., NO PART THEREOF MAY BE REPRODUCED AND USED WITHOUT THE PRIOR WRITTEN CONSENT OF THE OWNER

深圳市冠成电子有限公司